

netsys

Networking your world

NHG-200C

2Gbps G.hn EoC Endpoint

USER'S MANUAL



[Http://www.netsys.com.tw](http://www.netsys.com.tw)

Copyright

Copyright © 2024 by National Enhance Technology Corp. All rights reserved.

Trademarks

NETSYS is a trademark of National Enhance Technology Corp.

Other brand and product names are registered trademarks or trademarks of their respective holders.

Legal Disclaimer

The information given in this document shall in no event be regarded as a guarantee of conditions or characteristics. With respect to any examples or hints given herein, any typical values stated herein and/or any information regarding the application of the device, National Enhance Technology Corp. hereby disclaims any and all warranties and liabilities of any kind, including without limitation warranties of non-infringement of intellectual property rights of any third party.

Statement of Conditions

In the interest of improving internal design, operational function, and/or reliability, NETSYS reserves the right to make changes to the products described in this document without notice. NETSYS does not assume any liability that may occur due to the use or application of the product(s) or circuit layout(s) described herein.

Maximum signal rate derived from IEEE Standard specifications. Actual data throughput will vary. Network conditions and environmental factors, including volume of network traffic, building materials and construction, and network overhead, lower actual data throughput rate. Netsys does not warrant that the hardware will work properly in all environments and applications, and makes no warranty and representation, either implied or expressed, with respect to the quality, performance, merchantability, or fitness for a particular purpose. Make sure you follow in line with the environmental conditions to use this product.

Foreword

Attention:

Be sure to read this manual carefully before using this product. Especially Legal Disclaimer, Statement of Conditions and Safety Warnings.

The Netsys' NHG-200C is a 2 Giga LAN over 1.7 Gbps Coax endpoint, the idea of design by G.hn Wave-2 technology for higher than Gigabit-grade networking. The design can be used for home networking access applications. As endpoint networking gear it can be used to extend the house LAN over the existing TV cable, delivering Giga-grade connectivity for IP surveillance or secondary WiFi AP. Suitable for Point to Ethernet over Coax installation in point to point or point to multipoint networking access. The coaxial interface includes two 75Ω F-connectors for G.hn & TV ports with built in diplexer, so as to allow sharing the same coaxial outlet with a TV set.

Caution:

The NHG-200C is for **indoor** applications only. This product does not support waterproof protection, please do not install on outdoor environment. .

Safety Warnings

For your safety, be sure to read and follow all warning notices and instructions before using the device.

- ◆ **DO NOT** open the device or unit. Opening or removing covers can expose you to dangerous high voltage points or other risks. ONLY qualified service personnel can service the device. Please contact your vendor for further information.
- ◆ **Use ONLY** the dedicated power supply for your device. Connect the power to the right supply voltage (110V AC used for North America and 230V AC used for Europe).
- ◆ **Place** connecting cables carefully so that no one will step on them or stumble over them. DO NOT allow anything to rest on the power cord and do NOT locate the product where anyone can work on the power cord.
- ◆ **DO NOT** install nor use your device during a thunderstorm. There may be a remote risk of electric shock from lightning.
- ◆ **DO NOT** expose your device to dampness, dust or corrosive liquids.
- ◆ **DO NOT** use this product near water, for example, in a wet basement or near a swimming pool.
- ◆ **Connect ONLY** suitable accessories to the device.
- ◆ **Make sure** to connect the cables to the correct ports.
- ◆ **DO NOT** obstruct the device ventilation slots, as insufficient air flow may harm your device.
- ◆ **DO NOT** place items on the device.
- ◆ **DO NOT** use the device for outdoor applications directly, and make sure all the connections are indoors or have waterproof protection place.
- ◆ **Be careful** when unplugging the power, because it may produce sparks.
- ◆ **Keep** the device and all its parts and accessories out of the reach of children.
- ◆ **Clean** the device using a soft and dry cloth rather than liquid or atomizers. Power off the equipment before cleaning it.
- ◆ This product is **recyclable**. Dispose of it properly.

Table of Contents

Copyright	1
Foreword	2
Safety Warnings.....	3
Table of Contents.....	4
Chapter 1. Unpacking Information	5
1.1 CHECK LIST.....	5
Chapter 2. Hardware Description.....	6
2.1 FRONT PANEL	6
2.2 LED INDICATORS.....	7
2.3 REAR PANEL	8
Chapter 3. Installation	10
3.1 HARDWARE INSTALLATION	10
3.2 PRE-INSTALLATION REQUIREMENTS	10
3.3 GENERAL RULES	11
3.4 NHG-200C CONNECTIONS	12
Appendix A: Cable Requirements	14
Appendix B: Product Specifications	17
Appendix C: Troubleshooting.....	20
Appendix D: FCC and CE Mark Warning	26
Appendix E: Attaching Rubber Feet	30
Warranty	31
Chinese SJ/T 11364-2014	32

Chapter 1. Unpacking Information

1.1 Check List

Carefully unpack the package and check its contents against the checklist.

Package Contents

- 1 x NHG-200C
- 1 x AC to DC **12V** / 1A Power Adapter
- 4 x Rubber Feet
- 1 x RJ-45 Cable

Notes:

1. Please inform your dealer immediately for any missing or damaged parts. If possible, retain the carton including the original packing materials. Use them to repack the unit in case there is a need to return for repair.
2. If the product has any issue, please contact your local vendor.
3. Do not use sub-standard power supply. Before connecting the power supply to the device, be sure to check compliance with the specifications. The NHG-200C supports 12 VDC power input.
4. The power supply included in the package is commercial-grade. Do not use in industrial-grade applications.
5. Please look for the QR code on the bottom of the product, the user can launch the QR code scanning program to scan and download the user's manual electronic format file.

Chapter 2. Hardware Description

This section describes the important parts of the NHG-200C. It features the front indicators and rear connectors.



NHG-200C Outward

2.1 Front Panel

The front panel provide interface symbols corresponding to the LED indicators of the NHG-200C shown as [Figure 2.1](#)



Figure 2.1: NHG-200C Front Panel





2.2 LED indicators

At a quick glance of the front panel, it will be easy to indicate that the NHG-200C has good power, and 2 Ethernet RJ-45 port of link / 1G indicate Link and speed status, and G.hn port of link quality LED indicates high / middle / low speed.

Front Indicators

The NHG-200C support **8** indicated LEDs. The following Table shows as the description. ([Table 2-1](#))

Table 2-1: LED Indicators Description and Operation

LEDs	Color	Status	Descriptions
	Green	On	G.hn system power good and also functioning properly.
		Off	G.hn is not ready or has malfunctioned.
EthA & EthB (Link LED)	Green	On	Ethernet link is up.
		Blinking	Transmit or receive activity.
		Off	Ethernet link is down.
	Green	On	Transmission Data AES-128 encrypted
		Off	Transmission Data unencrypted
	Green	On	G.hn data rate > 1000Mbps by upstream plus downstream bandwidth.
	Green Yellow	On On	G.hn data rate between 600Mbps and 1000Mbps by upstream plus downstream bandwidth.
	Yellow	On	G.hn data rate < 600Mbps by upstream plus downstream bandwidth.

2.3 Rear Panel

- The rear panel provides the physical connectors for connecting to the power adapter and any other network device. The following of the rear side outward of the NHG-200C shown as [Figure 2.2](#)



Figure 2.2

- Connecting interface description shown as Table 2-3

Connectors	Type	Description
G.hn	F-type female coaxial cable	For connecting multiple NHG-200C over RG59U 75Ω coaxial cable.
TV	F-type female coaxial cable	For connecting to Cable TV or STB.
LAN1/LAN2	RJ-45	For connecting to an Ethernet device or PC.
Power	DC Power Jack	For connecting to 12VDC / 1A power adapter, regarding the NHG-200C power specification you can refer to serial sticker of the bottom.

Table 2-3

Chapter 3. Installation

3.1 Hardware Installation

This chapter describes how to install the NHG-200C and establish the network connections. You may install the NHG-200C on any level surface (ex. a table or shelf). However, please take note of the following minimum site requirements before you begin. **NHG-200C needs paste four rubber feet on the bottom to avoid scratching, please refer to Appendix E: Attaching Rubber Feet.**

3.2 Pre-installation Requirements

Before the start of actual hardware installation, make sure to provide the right operating environment, including power requirements, sufficient physical space, and proximity to other network devices that are to be connected. Verify the following installation requirement:

- Power requirements: **12VDC / (1A or above)**
- The device should be located in a **cool dry place**, with at least **10cm / 4in** of space at the front and back for ventilation.
- Place the device away from **direct sunlight, heat sources**, or areas with a high amount of electromagnetic interference.
- Check if network cables and connectors needed for installation are available.
- **Avoid installing this device with radio amplifying station nearby or transformer station nearby.**

3.3 General Rules

Before making any connections to the NHG-200C, take note the following rules:

- **Ethernet Port (RJ-45)**

All network connections to the end point Ethernet ports must be made using Category 5 UTP or above for 100 Mbps, Category 3, 4 UTP for 10Mbps.

No more than 100 meters of cabling maybe use between the MUX or HUB and an end node.

- **G.hn Port (Coaxial connector)**

All Home network connections we recommend use RG-59 75 Ω coaxial cable and link establish under -160dBm/Hz noise floor.

- **Multi-Splitter**

All Home network connections could be use Multi-Splitter or use mix of them as you would like to connect an end point device.



Multi-Splitter

3.4 NHG-200C Connections

The NHG-200C has been designed to operate on the coaxial cable installed in homes throughout the world. They utilized the same cable and connectors commonly used for television.

The NHG-200C support 2 x Giga Ethernet ports. One port is used to connect to the ISP to provide Internet access and another port is used to connect devices such as Switch, WiFi AP, PC. The device attached to these ports must support auto-negotiation and auto MDIX.

The 2x Coaxial connector are used to connect to TV or coaxial wall socket to another NHG-200C that connect its RJ-45 to the LAN card of another set of PC, notebook, or other internet access device or coaxial connector to TV or set top box.

The NHG-200C's coaxial connector must support the transmission of data up to 1700Mbps across the existing coaxial cable and link establish under **-76db** attenuation. But make sure that the connector is inserted properly and lock. Ethernet cable used must conform to FCC standard to ensure data integrity and it should not exceed **100meters** (328feet).

The NHG-200C supports up to **16**(maximum) NHG-200C Endpoint devices.

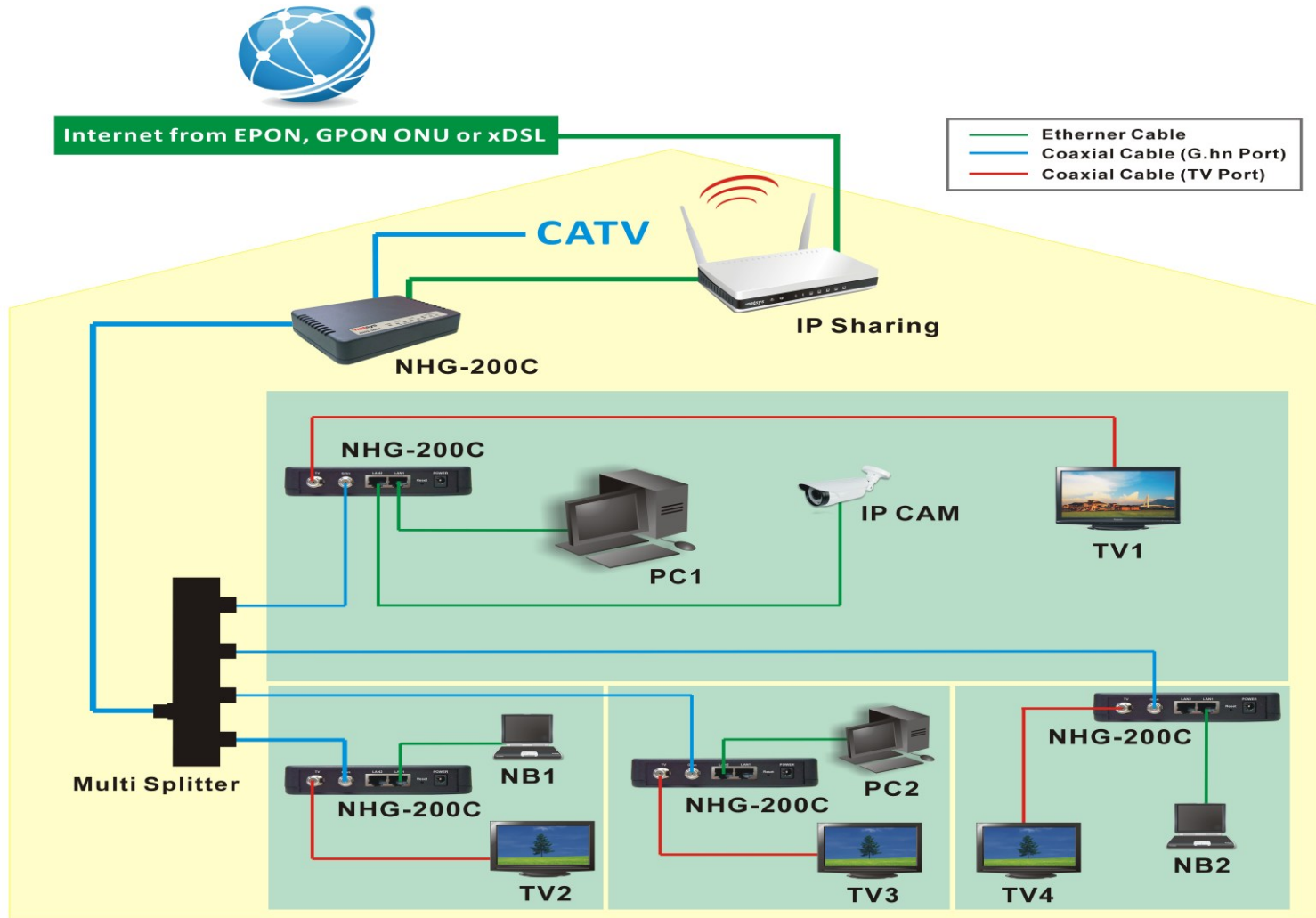

Figure 3.1: NHG-200C Home Network Diagram

Appendix A: Cable Requirements

Ethernet Cable

A CAT 5~7 UTP (unshielded twisted pair) cable is typically used to connect the Ethernet device to the Modem. A: 10/100TX cable often consists of four pairs of wires, two of which are used for transmission. The connector at the end of the 10/100TX cable is referred to as a RJ-45 connector and it consists of eight pins. The Ethernet standard uses pins 1, 2, 3 and 6 for data transmission purposes. (Table A-1 10/100TX)

B: 1000TX cable often consists of four pairs of wires, all of which are used for transmission. The connector at the end of the 1000TX cable is referred to as a RJ-45 connector and it consists of eight pins. The Ethernet standard uses pins 1, 2, 3, 4, 5 and 6 for data transmission purposes. (Table A-1 1000TX)

Table A-1 RJ-45 Ethernet Connector Pin Assignments

PIN #	10/100TX		1000TX	
	Signal	Media Dependant interface	Signal	Media Dependant interface-cross
1	TX+	Transmit Data+	BI_DA+	Bi-directional pair A+
2	TX-	Transmit Data-	BI_DA-	Bi-directional pair A-
3	RX+	Receive Data+	BI_DB+	Bi-directional pair B+
4	NC	Unused	BI_DC+	Bi-directional pair C+
5	NC	Unused-	BI_DC-	Bi-directional pair C-
6	RX-	Receive Data-	BI_DB-	Bi-directional pair B-
7	NC	Unused	BI_DD+	Bi-directional pair D+
8	NC	Unused	BI_DD-	Bi-directional pair D-

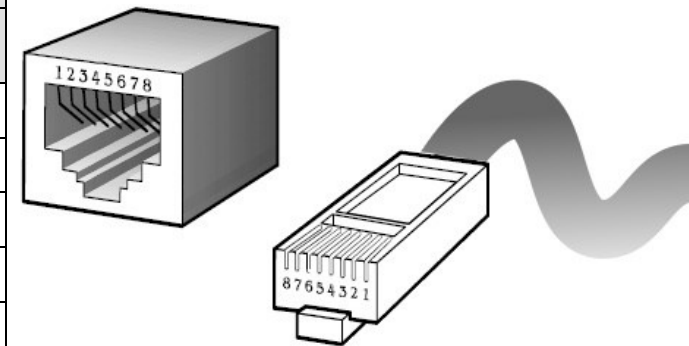

Figure A-1 Standard RJ-45 receptacle /connector

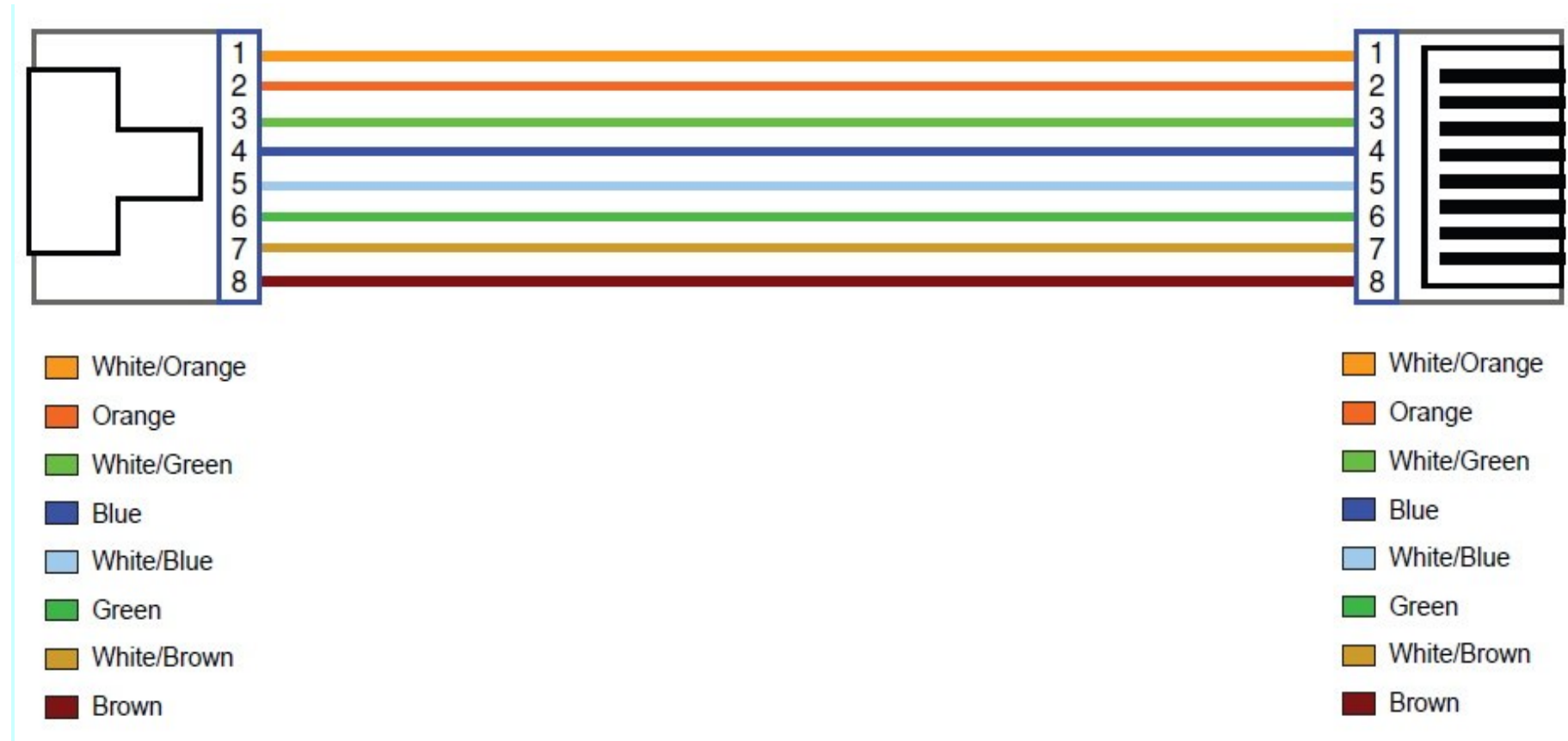

Figure A-2 Pin Assignments and Wiring for an RJ-45 Straight-Through Cable

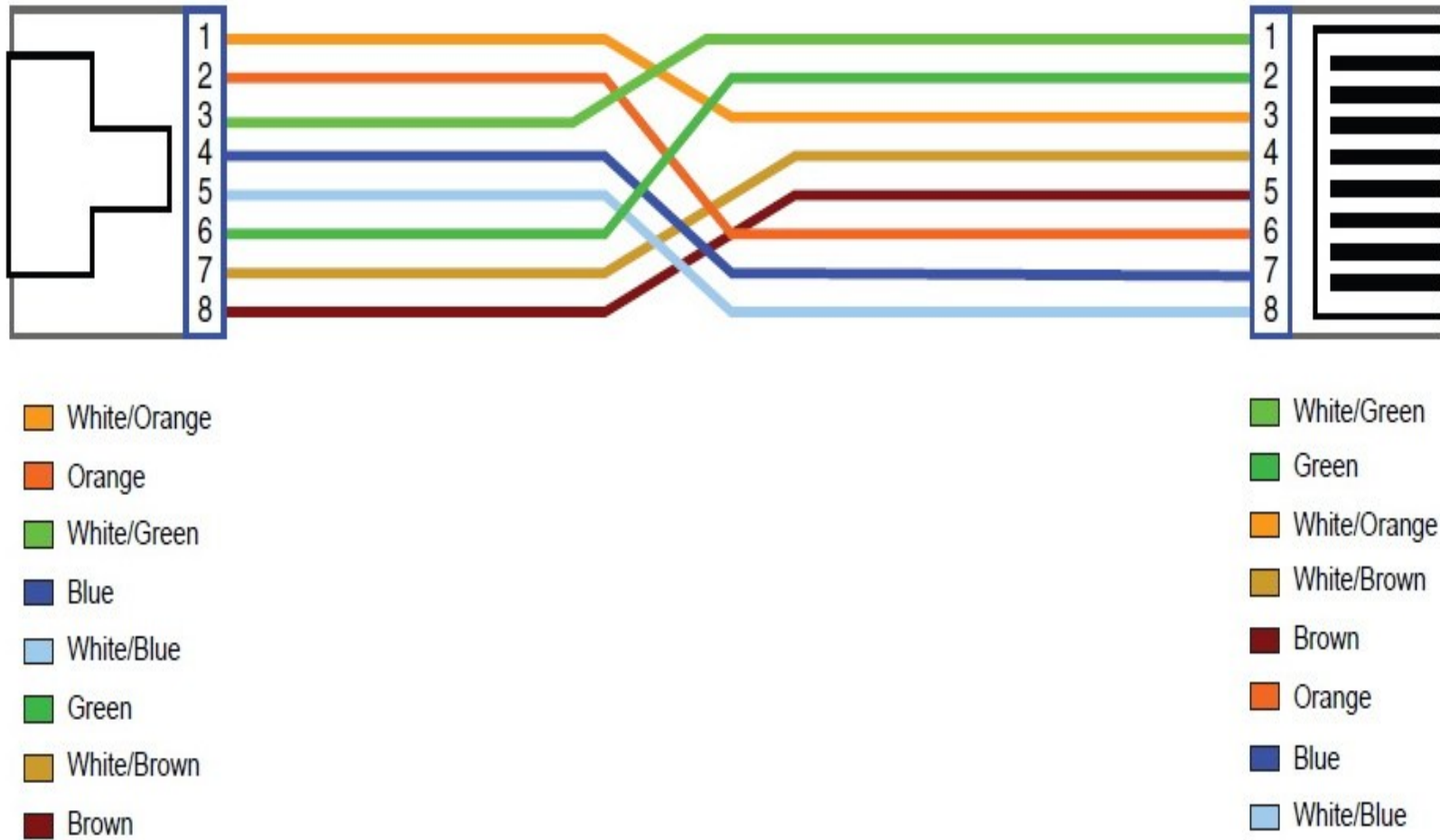

Figure A-3 Pin Assignments and Wiring for an RJ-45 Crossover Cable

Appendix B: Product Specifications

Key Features & Benefits

- Compliant with G.hn ITU-T G.9960/9961/9962/9964 standard
- Compliant with IEEE802.3 10Base-T & IEEE802.3u 100Base-TX & IEEE802.3ab 1000Base-T standard
- Compliant with IEEE802.3x flow control standard
- Provides 2 x 10/100M/1000M auto-negotiation RJ-45 Ethernet ports with auto-MDI/MDIX
- Provides 2 x F-type female coaxial connectors for G.hn and TV ports
- Supports transmission speed up to 1700Mbps over coaxial cable
- Supports AES-128 encryption with individual key
- Supports attenuation up to -76db for G.hn port
- Supports point to point and point to multipoint application
- Supports IEEE802.1p priority mapping
- Supports IEEE802.1p/TOS priority queue
- Supports IEEE802.1Q Tag VLAN pass through
- Supports auto-speed & link quality indication
- Supports up to 16 endpoints connection
- Built in surge protector for G.hn port
- EMI / EMS certificate by FCC & CE

Product Specifications

Standards:	IEEE802.3/u/ ab & ITU-T G.9960/9961/9962/9964 standard
Interfaces:	2 x RJ-45, 10/10/1000 Mbps Ethernet port with Auto-Negotiation 1 x F-type female coaxial connector for G.hn 1 x F-type female coaxial connector for STB/TV 1 x Power jack for 12VDC / 1A power adapter.
Bandwidth:	Up to 1700Mbps
Attenuation	Up to -76db
LED Indicators:	1 x Power LED 2 x Ethernet "Link/Activity" LEDs 2 x Ethernet Giga Speed LED 1 x G.hn security LED 2 x G.hn Link Quality LED
G.hn port transmission spectrum:	5Mhz ~ 200Mhz
TV port pass spectrum	250Mhz ~ 1.2Ghz
Power consumption	Typical 3.9 watts
Weight	161g
Dimensions:	130mm x 94.5mm x 27mm (5.12" x 3.72" x 1.06") (L x W x H)

NHG-200C 2Gbps G.hn EoC Endpoint USER'S MANUAL Ver. A3

Temperature:	Operating: 0°C ~ 50°C (32°F ~ 122°F) Storage: -20°C ~ 70°C (-4°F ~ 158°F)
Humidity:	10% ~ 90% non-condensing
External Power Adapter:	12VDC / 1A for commercial type adapter
EMI / EMS Certificate	FCC Class-A / CE Class-A

Appendix C: Troubleshooting

Diagnosing the NHG-200C's Indicators

The endpoint can be easily monitored through its comprehensive panel indicators. These indicators assist the network manager in identifying problems the hub may encounter. This section describes common problems you may encounter and possible solutions.

1. Symptom:	POWER indicator does not light up (green) after power on.
Cause:	Defective External power supply
Solution:	Check the power plug by plugging in another that is functioning properly. Check the power adapter with another device. If these measures fail to resolve the problem, have the unit power supply replaced by a qualified distributor.
2. Symptom:	Link indicator does not light up (green) after making a connection.
Cause:	Network interface (ex. a network adapter card on the attached device), network cable, or switch port is defective.
Solution:	2.1 Verify that the endpoint and attached device are powered on. 2.2 Make sure the cable is plugged into both NHG-200Cs and corresponding device. 2.3 Verify that the proper cable type is used and its length does not exceed specified limits. 2.4 Check the NHG-200C on the attached device and cable connections for possible defects. 2.5 Check connection node if over 16 endpoint devices or attenuation over -76db 2.6 Replace the defective NHG-200C or cable if necessary.

NHG-200C 2Gbps G.hn EoC Endpoint USER'S MANUAL Ver. A3

3. Symptom:	G.hn quality LEDs do not light up green only, LEDs light up both green and yellow after making a connection.
Cause:	It is a normal indication of the device; link quality LEDs light up depending on transmission signal PSD level
Solution:	Link quality LEDs : Only green LED light up indicates link speed over 1000Mbps Green and Yellow both LEDs light up indicates link speed between 600Mbps and 1000Mbps Only yellow LED light up indicates link speed less than 600Mbps
4. Symptom:	I connect TV signal to NHG-200C, why TV signal can't show on TV
Cause:	TV signal is too weak or other factors.
Solution:	Please verify that the following items to help you clarify the problem: 1. Verify coaxial cable must use RG59/u 75 Ω cable. 2. Verify TV signal source and TV if available. 3. Check TV signal need to over 250MHz that will be passed. 4. Add TV signal repeater if TV signal source is too weak. 5. Add attenuator before TV if TV signal is too strong.
Notes:	1. Weakened by the output television signal is due to environmental factors. NHG-200C supports TV signal pass through, but can not guarantee to be able to maintain an appropriate TV signal output to TV, If the connection distance is too long lead to output of TV signal no signal or attenuation. 2. Please note that NHG-200C TV signals input power is unlimited, user does not need add the attenuator before NHG-200C to weaken the TV signal source. 3. If TV signal is too strong, leading to the advent of television ripple, please add an attenuator before TV.

Figure C-1 TV signal connection solution

NHG-200C 2Gbps G.hn EoC Endpoint USER'S MANUAL Ver. A3

5. Question:	Why do the NHG-200C units have MAC addresses and what are the MAC Addresses used for?
Answer:	NHG-200C can support up to 16 endpoints connections and It uses different MAC address for identifying each endpoint.

System Diagnostics

Power and Cooling Problems

If the POWER indicator does not turn on when the power cord is plugged in, you may have a problem with the power outlet, power cord, or internal power supply as explained in the previous section. However, if the unit power is off after running for a while, check for loose power connections, power losses or surges at the power outlet, and verify that the fan on back of the unit is unobstructed and running prior to shutdown. If you still cannot isolate the problem, then the internal power supply may be defective. In this case, please contact your local dealer.

Installation

Verify that all system components have been properly installed. If one or more components appear to be malfunctioning (e.g., the power cord or network cabling), test them in an alternate environment where you are sure that all the other components are functioning properly.

Transmission Mode

The default method of selecting the transmission mode for RJ-45 ports is 10/100 Mbps Ethernet, for coaxial connectors are 200Mbps G.hn. It supports auto-negotiation and is **half-duplex**. Therefore, if the link signal is disrupted (e.g. by unplugging the network cable and plugging it back in again, or by resetting the power), the port will try to reestablish communications with the attached device via auto-negotiation. If the device does not support auto-negotiation, communications can be easily lost (i.e., reset to the wrong mode) whenever the attached device is reset or experiences a power fluctuation. The best way to resolve this problem is to upgrade these devices to a version that support Ethernet and 200Mbps G.hn.

Physical Configuration

If problems occur after altering the network configuration, restore the original connections, and try to track the problem down by implementing the new changes, one step at a time. Ensure that cable distances and other physical aspects of the installation that do not exceed recommendations.

System Integrity

As a last resort verify the switch integrity with a power-on reset. Turn the power to the switch off and then on several times. If the problem still persists and you have completed all the preceding diagnoses, then contact your dealer.

Examples of a Compression F-Connector

CORRECT CONNECTOR CONDITION:

A. Stinger is right length – it protrudes a bit beyond the rim.

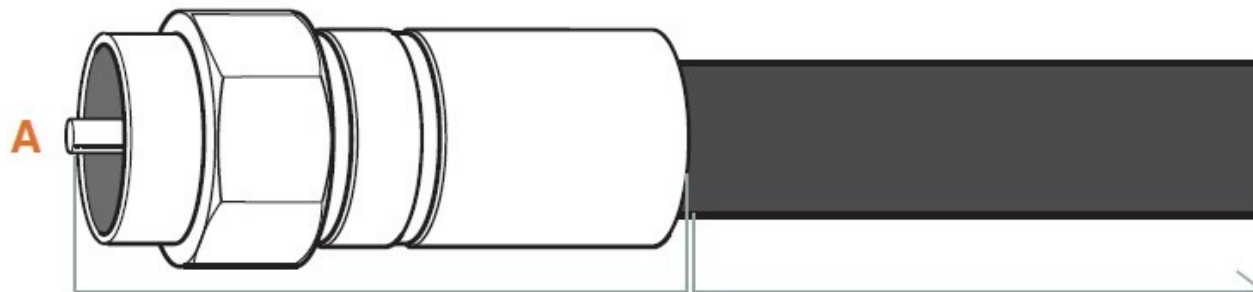

Metal Fittings:

Check for signs of rust or corrosion; replace if necessary

Coax Line:

Visually check visible coax for nicks, splits, and tangling

AVOID THESE BAD CONDITIONS:

- B.** Low dielectric – a gap between the dielectric and ridge will cause packet loss; dielectric should be flush with the ridge.
- C.** Debris inside connector – for example, loose shielding strands wrapped around the stinger will cause 30dB attenuation.

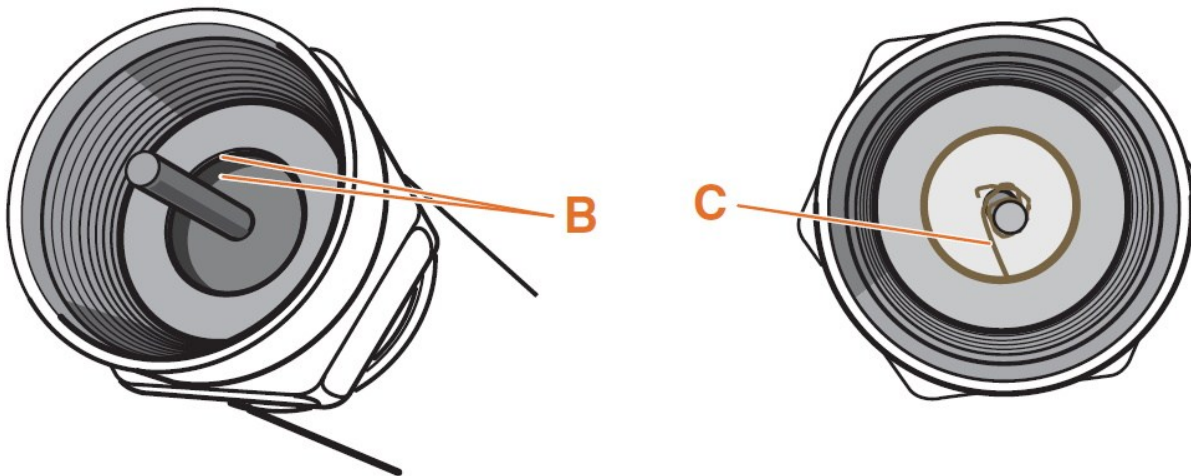

Note:

Please note that user need use RG59 75ohm coaxial cable to establish Home network.

Appendix D: FCC and CE Mark Warning

FCC Radio Frequency Interference Statement

This equipment has been tested and found to comply with the limits for a computing device, pursuant to Part 15 of FCC class A rules. These limits are designed to provide reasonable protection against harmful interference when the equipment is operated in a commercial environment. This equipment generate, uses and can radiate radio frequency energy and, if not installed and used in accordance with the instructions, may cause harmful interference to radio communications. However, there is no guarantee that interference will not occur in a particular installation. If this equipment does cause harmful interference to radio or television reception, which can be determined by turning the equipment off and on, the user is encouraged to try to correct the interference by one or more of the following measures:

1. Reorient or relocate the receiving antenna.
2. Increase the separation between the equipment and receiver.
3. The equipment and the receiver should be connected to outlets on separate circuits.
4. Consult the dealer or an experienced radio/television technician for help.

Changes or modifications not expressly approved by the party responsible for compliance could void the user's authority to operate the equipment.

If this telephone equipment causes harm to the telephone network, the telephone company will notify you in advance that temporary discontinuance of service may be required. But if advance notice isn't practical, the telephone company will notify the customer as soon as possible. Also, you will be advised of your right to file a complaint with the FCC if you believe it is necessary.

The telephone company may make changes in its facilities, equipment, operations or procedures that could affect the

proper functioning of your equipment. If they do, you will be notified in advance in order for you to make necessary modifications to maintain uninterrupted service.

This equipment may not be used on coin service provided by the telephone company. Connection to party lines is subject to state tariffs.

Important Safety Instructions

- ◆ **Caution:** The direct plug-in wall transformer serves as the main product for disconnecting. The socket outlet shall be installed near the product and be readily accessible.
- ◆ **Caution:** Use only the power supply included with this product. In the event the power supply is lost or damaged: In the United States, use only with CSA certified or UL listed Class 2 power supply, rated **12Vdc 1A** or above.
IN Europe, use only with CE certified power supply, rated **12Vdc 1A** or above.
- ◆ **Do not** use this equipment near water, for example in a wet basement.
- ◆ **Avoid** using a telephone during an electrical storm. There may be a remote risk of electrical shock from lightning.
- ◆ **Do not** use the telephone to report a gas leak in the vicinity of the leaking area.
- ◆ If you experience trouble with this unit, please contact customer service of your dealer immediately.
- ◆ **DO NOT DISASSEMBLE THIS EQUIPMENT.** It does not contain any user serviceable components.

FCC Warning



This equipment has been tested to comply with the limits for a Class A digital device, pursuant to Part 15 of the FCC Rules. These limits are designed to provide reasonable protection against harmful interference when the equipment is operated in a commercial environment. This equipment can generate, use, and radiate radio frequency energy and, if not installed and used in accordance with the instruction manual, may cause harmful interference to radio communications. Operation of this equipment in a residential area is likely to cause harmful interference in which case the user will be required to correct the interference at owner's expense.

CE Mark Warning



This is a class A product. In a domestic environment, this product may cause radio interference in which case the user may be required to take adequate measures.

RoHS Mark Warning



RoHS stands for Restriction of Hazardous Substances, and impacts the entire electronics industry and many electrical products as well. The original RoHS, also known as Directive 2002/95/EC, originated in the European Union in 2002 and restricts the use of six hazardous materials found in electrical and electronic products. All applicable products in the EU market since July 1, 2006 must pass RoHS compliance. Directive 2011/65/EU was published in 2011 by the EU, which is known as RoHS-Recast or RoHS 2. RoHS 2 includes a **CE-marking directive**, with RoHS compliance now being required for CE marking of products. RoHS 2 also added Categories 8 and 9, and has additional compliance recordkeeping requirements. Directive 2015/863 was published in 2015 by the EU, which is known as RoHS 3. RoHS 3 adds four additional restricted substances (phthalates) to the list of six.

WEEE Warning



To avoid the potential effects on the environment and human health as a result of the presence of hazardous substances in electrical and electronic equipment, end users of electrical and electronic equipment should understand the meaning of the crossed-out wheeled bin symbol. Do not dispose of WEEE as unsorted municipal waste and have to collect such WEEE separately.

Appendix E: Attaching Rubber Feet

1. Make sure mounting surface on the bottom of the NHG-200C is grease and dust free.
2. Remove adhesive backing from your Rubber Feet.
3. Apply the Rubber Feet to each corner on the bottom of the NHG-200C. These footpads protect the NHG-200C from shock and vibration.

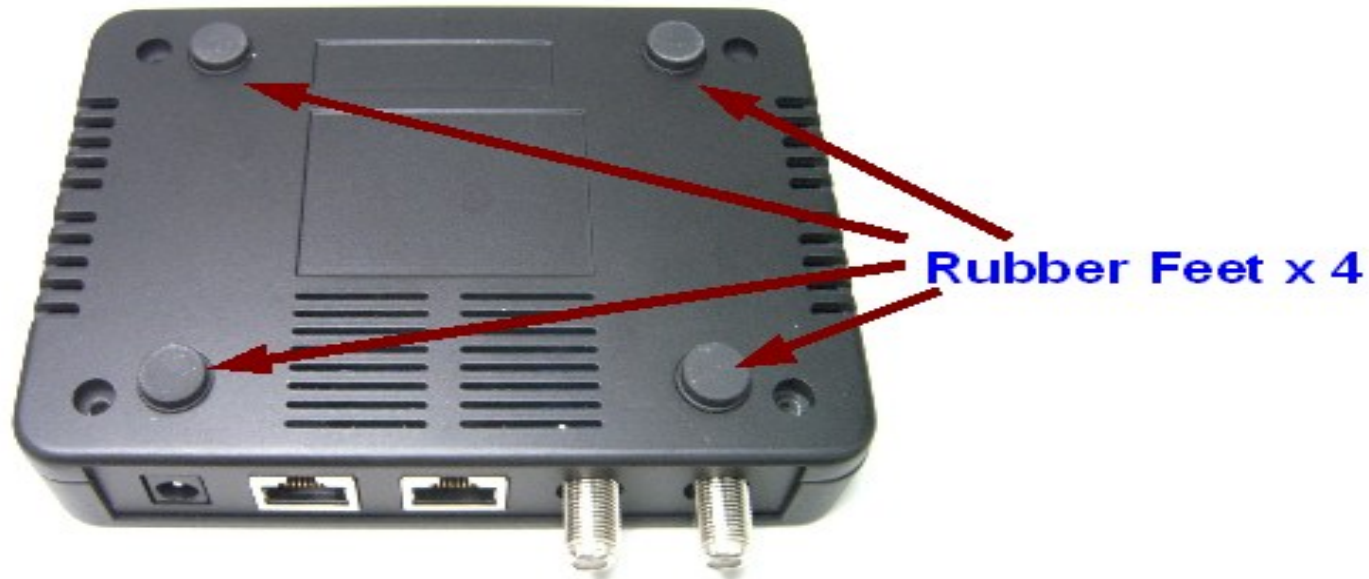

Warranty

The original owner that the product delivered in this package will be free from defects in material and workmanship for two years parts after purchase.

There will be a minimal charge to replace consumable components, such as fuses, power transformers, and mechanical cooling devices. The warranty will not apply to any products which have been subjected to any misuse, neglect or accidental damage, or which contain defects which are in any way attributable to improper installation or to alteration or repairs made or performed by any person not under control of the original owner.

The above warranty is in lieu of any other warranty, whether express, implied, or statutory, including but not limited to any warranty of merchantability, fitness for a particular purpose, or any warranty arising out of any proposal, specification, or sample. We shall not be liable for incidental or consequential damages. We neither assume nor authorize any person to assume for any other liability.

WARNING
Warranty Void
If Removed

WARNING:

- 1. DO NOT TEAR OFF OR REMOVE THE WARRANTY STICKER AS SHOWN, OR THE WARRANTY IS VOID.**
- 2. WARRANTY VOID IF USE COMMERCIAL-GRADE POWER SUPPLY IS USED AT HARSH ENVIRONMENTS.**

Chinese SJ/T 11364-2014

部件名称	有毒有害物质或元素					
	铅(Pb)	汞(Hg)	镉(Cd)	六价铬[Cr(VI)]	多溴联苯(PBB)	多溴二苯醚(PBDE)
结构壳体	○	○	○	○	○	○
电路组	○	○	○	○	○	○
电源供应器	○	○	○	○	○	○
线材	○	○	○	○	○	○
包装及配件	○	○	○	○	○	○
○：表示该有毒物质在该部件所有均质材料中的含量均在 GB/T 26572 标准规定的限量要求以下。 ×：表示该有毒物质至少在该部件的某依均质材料中的含量超出 GB/T 26572 标准规定的限量要求。						

上述规范仅适用于中国法律